

Solar-Powered LED Marine Lanterns Model M702-5

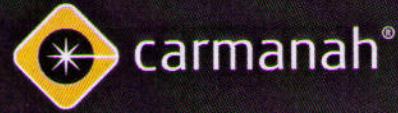

Side View

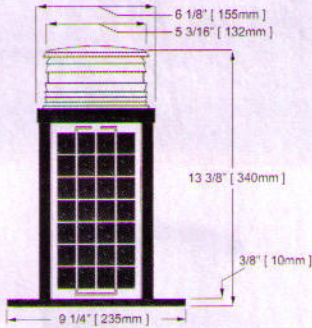

Top View

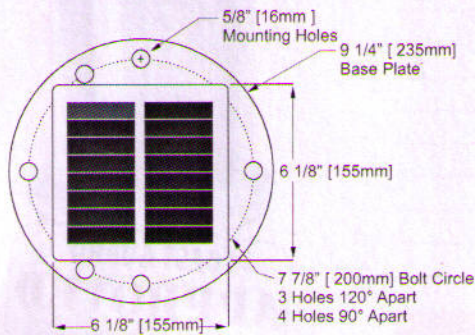

Accessories

Infrared Programmer



Security Bolt



Bird Deterrent



- Self-cleaning solar dome**
Self-cleaning solar dome that protects the solar panel, increases solar-charging efficiency and reduces the need for a bird deterrent (although, a bird deterrent is still available as an option).
- Ultra-bright LEDs**
Uses an array of bright light emitting diodes (LEDs) - no bulbs to replace, ever.
- Completely self-contained**
The solar panels, batteries and LEDs are brought together into one unique product.
- Sealed Unit**
Waterproof and vandal resistant.
- Multiple mounting patterns**
Features 3, 4, and 5-bolt mounting patterns.
- Automatically turns on and off**
On at dusk and off at dawn.

Originally designed and built under contract with the U.S. Coast Guard, Carmanah 700 series lanterns are the first solar-powered lanterns using light emitting diodes (LEDs) to enter the U.S. Navigational Aid System.

- **Maximum capacity with minimal life-cycle cost** – operates up to 5 years maintenance free¹
- **Field-proven durability** – over 250,000 solar installations worldwide
- **IP68 certification** – designed to higher levels of water ingress protection standards
- **Vandal and theft resistant design** – high quality construction and mounting hardware
- **Patented technology** – innovative LED technology and energy management system
- **Synchronization Module** – optional GPS capabilities, enables two or more M702-5 lanterns to flash in unison

The Model M702-5 is also:

- Manufactured in accordance with ISO 9001:2000 Quality Assurance Standards
- Engineered to meet requirements of the USCG in 33 CFR part 66 for Private Aids to Navigation
- Manufactured with a colored base plate for easy identification of LED color.

¹ Transmissivity of 0.74

² Actual range is dependant on flash pattern, intensity, and LED color.

³ Dependent on location.



Toll Free Canada & US: 1.877.722.8877 • carmanah.com • Worldwide: +1.250.380.0052